



## ARTFUL DODGERS AT PEACH BOTTOM

In January 2010, workers at the Peach Bottom nuclear plant in Pennsylvania tested control rods in the Unit 2 reactor to see how long it took to rapidly insert, or scram, them into the core. The test results were slow, slow, and slow:

- More than ten percent of the control rods took longer to insert than allowed by safety requirements.
- The problems with the control rods were caused by the company being slow to replace components it knew could cause these problems.
- The control room operators were slow to connect-the-dots and failed to shut down the reactor as mandated by the plant's operating license when tests find too many control rods failing to scram quickly enough.

Fortunately, this slow trilogy did not result in harm to plant workers or the public. However, the scram tests uncovered more than slow control rods—they also uncovered poor safety practices and a disregard for safety regulations by Peach Bottom's operators.

### BACKGROUND

Each of the two boiling water reactors operating at Peach Bottom has 185 control rods and 764 fuel bundles. The control rods contain boron, a material that readily absorbs neutrons. When uranium and plutonium atoms within the fuel bundles split apart to produce energy, neutrons are released. When those neutrons interact with other uranium and plutonium atoms, additional atom splitting can occur. This is called a nuclear chain reaction. Control rods govern the nuclear chain reaction rate, and hence the power level of the reactor core. Complete insertion of all control rods terminates the nuclear chain reaction and shuts down the core.

A control rod is moved using a hydraulic piston depicted by the cross-hatched inverted T inside the large rectangle in the figure. The rectangle represents the cylinder housing the piston, and the vertical part of the inverted T is connected to the control rod, which is above the piston. The piston is attached to the bottom of the reactor pressure vessel that houses the reactor core.

Four directional control valves, labeled 120 through 123, are used to insert and withdraw a control rod under normal

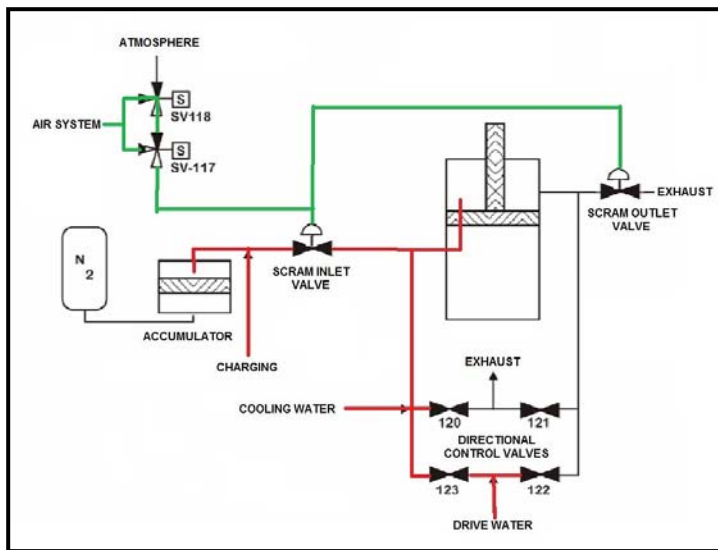

conditions. The directional control valves are normally closed, and they open when signals are sent to their electric motors.

A pair of scram valves, one inlet and one outlet, are used to insert a control rod under emergency conditions. The scram valves are normally closed. The scram valves have springs that will force them open unless enough air pressure is supplied to overcome the spring forces (about 50 pounds per square inch).

During normal reactor operation when the control rods are not being moved, a small amount of cooling water (about a quart per minute) flows into the region beneath each control rod piston. This flow rate is not enough to move the piston, but it is enough to cool the seal between the piston and the cylinder housing it.

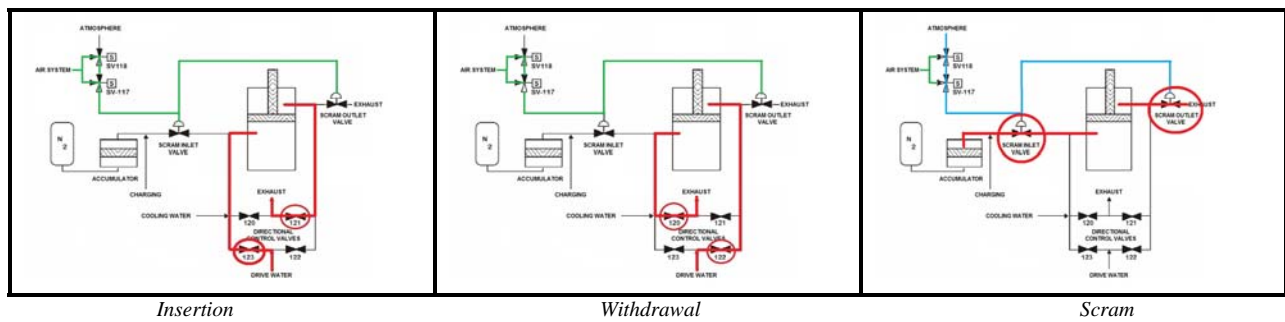

To insert a control rod under normal conditions, the operator would open directional control valves 121 and 123. This provides a pathway for drive water to be supplied to the volume beneath the piston and another pathway for water to be removed from the volume above the piston. The differential pressure moves the piston upward and the control rod into the reactor core.

To withdraw a control rod under normal conditions, the operator would open directional control valves 120 and 122. This provides a pathway for drive water to be supplied to the volume above the piston and another pathway for water to be removed from the volume beneath the piston. The differential pressure moves the piston downward and the control rod out of the reactor core.

To scram a control rod, two solenoid valves (labeled SV-117 and SV-118) open to vent air from the piping going to the scram inlet and outlet valves. When the air pressure in that piping drops low enough, the springs cause the scram inlet and outlet valves to open. This provides a pathway for water from the accumulator (a small tank of water pressurized by nitrogen to over 1,100 pounds per square inch) to be supplied to the volume beneath the piston and another pathway for water to be removed from the volume above the piston. The high differential pressure moves the piston upward and the control rod into the reactor core.

Workers are required to periodically time how long it takes individual control rods to scram from the fully withdrawn to the fully inserted positions. These tests verify that the reactor can be shut down in time to prevent damage to the nuclear fuel in event of an accident.

On January 29, 2010, the operators reduced the power level of the Peach Bottom Unit 2 reactor to 55 percent. Their plan was to test the scram time for 19 control rods. Each control rod is required to move from the fully withdrawn position (notch 48) to notch 46 within 0.44 seconds, then to notch 36 within 1.08 seconds, to notch 26 within 1.83 seconds, and to notch 6 within 3.35 seconds. Any control rod failing to meet these four time limits was officially considered “slow,” and the plant’s operating license permits only 7 percent of the control rods tested to be slow.

Three of the 19 control rods failed to reach notch 46 within 0.44 seconds, but met all other time limits. The test results showed that these control rods were slow to get moving, but moved fine once in motion. This clue led workers to discover the reason for the slow initial motion: parts within the solenoid valves (labeled SV-117 and SV118) had degraded and were partially blocking the vent pathway for the air supply to the scram inlet and outlet valves. As a result, it took longer for the air pressure to drop down below the point where spring forces would open the scram inlet and outlet valves. Once these valves did open, the control rods scrambled normally.

Because three is roughly sixteen percent of 19, workers needed to scram test additional control rods so that the slow rods accounted for seven percent or fewer of the rods tested. As they tested additional control rods, they uncovered more slow rods. They continued testing for three days until all 185 control rods had been tested at 3:00 PM on February 1, 2010. The results yielded 21 slow control rods, or eleven percent of the total.

The solenoid valve degradation problems had been identified in the mid-1990s. The vendor developed a part less vulnerable to degradation and had offered free replacements in 1997 under its warranty program. For some reason, Peach Bottom’s owner did not take advantage of the free safety upgrades and continued to operate with parts it had installed in 1995—despite knowing they were susceptible to degradation damage. Compounding that error, workers at Peach Bottom also failed to track the scram test results for individual control rods, which is commonly done at other nuclear plants. This information permits reactor operators to make informed decisions about replacement and repairs of control rod components. After the fact, workers at Peach Bottom reviewed the scram time results for the 21 slow control rods and saw clear warning signs of the pending failures.

3.1 REACTIVITY CONTROL SYSTEMS

3.1.4 Control Rod Scram Times

LCO 3.1.4 a. No more than 13 OPERABLE control rods shall be "slow," in accordance with Table 3.1.4-1; and

b. No more than 2 OPERABLE control rods that are "slow" shall occupy adjacent locations.

APPLICABILITY: MODES 1 and 2.

ACTIONS

CONDITION	REQUIRED ACTION	COMPLETION TIME
A. Requirements of the LCO not met.	A.1 Be in MODE 3.	12 hours

The third leg of the slow trilogy is the most troubling. The testing undertaken on January 29, 2010, was being performed to satisfy an explicit condition of the plant’s operating license. In particular, technical specification 3.1.4 required the periodic scram time testing to ensure that the reactor operated with no more than 13 slow control rods (which is seven percent of 185). If that

condition can not be met, the reactor is required to shut down within 12 hours. Yet Peach Bottom Unit 2 operated from January 29—when testing began—until February 1—when testing of all 185 control rods ended. It was not until February 3 that all repairs were completed and the 21 slow control rods re-tested to confirm that they were now operating properly.

Here's Oliver's Twist – the Peach Bottom operators artfully dodged around technical specification 3.1.4 by postponing control rod testing until they had repaired enough slow control rods to stay at or below 13 at any one time. So, instead of invoking Condition A of technical specification 3.1.4 when they identified the 14<sup>th</sup> slow control rod, which would have given them 12 hours to test the remaining control rods and reduce the number of slow ones to 13 or less, they slowed down control rod testing to match the repairs. That's why it took them three days to test all 185 control rods.

I scam tested all 185 control rods on several occasions when working as a reactor engineer and control rod drive system engineer at the Browns Ferry nuclear plant, a sister plant to Peach Bottom. It never took longer than a single 12-hour shift to scam time test all 185 control rods. Of course, we were not playing games with safety regulations as were the artful dodgers at Peach Bottom.

It is outrageous that the Peach Bottom operators played fast and loose with safety regulations. The operators' intentional skirting of safety requirements would not be tolerated by an effective regulator. My prediction: the NRC will do absolutely nothing about it.

Prepared by: David Lochbaum  
Director, Nuclear Safety Project

Sources:

1. Peach Bottom Unit 2, Current Facility Operating License DPR-56, Technical Specifications, February 29, 2008. (ML052720266)
2. Peach Bottom Unit 2, Technical Specification Bases, April 17, 2009. (ML091280608)
3. Exelon Corporation, Licensee Event Report 10-001-00, March 19, 2010. (ML1082080)
4. Nuclear Regulatory Commission, Inspection Report 05000277-10-002 and 05000278-10-002, May 12, 2010. (ML101320455)